

# INSTALLATION INSTRUCTIONS

## Please Note Before Installation

Hardware Resource Company (HRC) cannot control the use or installation of add-on, spare, or replacement parts. Therefore, HRC shall have no responsibility for injury or damage resulting from improper installation or other misuse. Parties undertaking use of these parts assume full responsibility for following proper installation procedures.

## Instructions for installing replacement connecting hardware kits.

- 1.) Ensure all electrical power and voltage has been turned off, locked off, and tagged out. Do not attempt to install product into a switchboard or panelboard while energized. Installation of this product should be performed by qualified personnel only.
- 2.) After electricity has been locked off and tagged out, confirm that no electrical current is present by using a calibrated voltage detection instrument.
- 3.) Remove dead front cover plates as necessary to gain access to work area.
- 4.) De-energized bus bar should now be exposed. Install the B phase (center phase) connector first.
- 5.) Tighten screws or bolts to finger tight at this point.
- 6.) Install out side phase connector(s), and tighten with fingers.
- 7.) Install bus bar anti-turn devices if provided. (Not all kits utilize anti-turn devices.)
- 8.) Install circuit breaker or switch mounting brackets if provided.
- 9.) If available, place the circuit breaker or switch into its intended location to verify proper alignment and fit. If not available, refer to the attached assembly drawings for proper dimensions and locations of components parts. (Circuit breaker or switch is not included in this kit.)
- 10.) After proper alignment has been verified, tighten all bus connections with a calibrated torque wrench to the values listed in table to the right. Check to be sure there are no visible obstructions or foreign materials present that might reduce proper electrical clearances, or damage insulated conductors. Remove any obstructions or foreign materials before continuing.
- 11.) If available, install circuit breaker or switch onto connectors.
- 12.) If not available, go to step 11.
- 13.) Install circuit breaker or switch filler plates when provided. (Some may not be required with twin-mounted breakers)
- 14.) Re-install dead front cover plates. Do not re-energize the switchboard or panelboard without first following all safety and procedural practices necessary to ensure it is safe to re-apply power to the equipment. Only qualified personnel shall re-energize any switchboard or panel board.

### Torque Values for Copper or Aluminum Bar Connections

| Bolt Size<br>Inch. (mm) | Torque<br>lb. - In. |
|-------------------------|---------------------|
| #10                     | 30                  |
| 1/4                     | (6.4) 65            |
| 5/16                    | (7.9) 128           |
| 3/8                     | (9.5) 240           |
| 1/2                     | (12.7) 600          |

### NOTICE

THE USE OF THE ORIGINAL MANUFACTURER'S TRADEMARK IS FOR INFORMATIONAL PURPOSES ONLY AND DOES NOT REPRESENT AN ENDORSEMENT OF THIS PRODUCT BY THE MANUFACTURER.

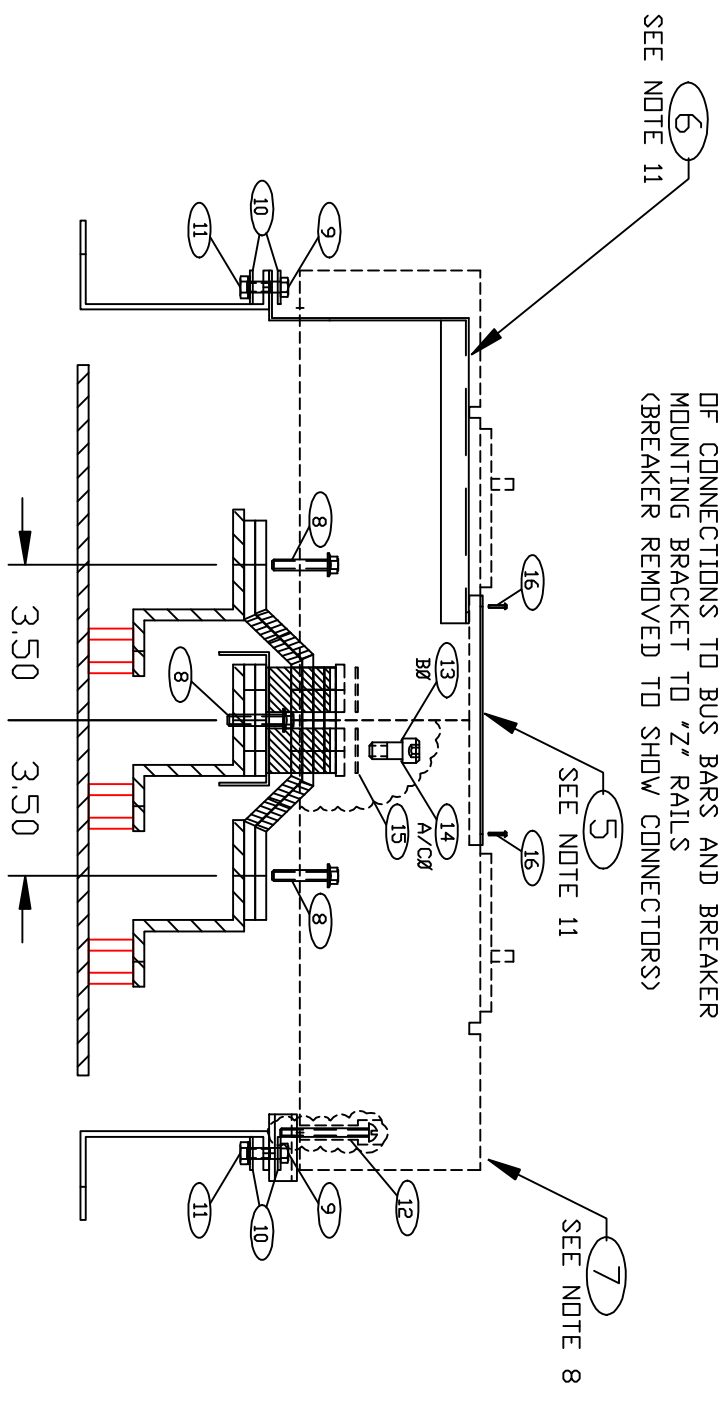
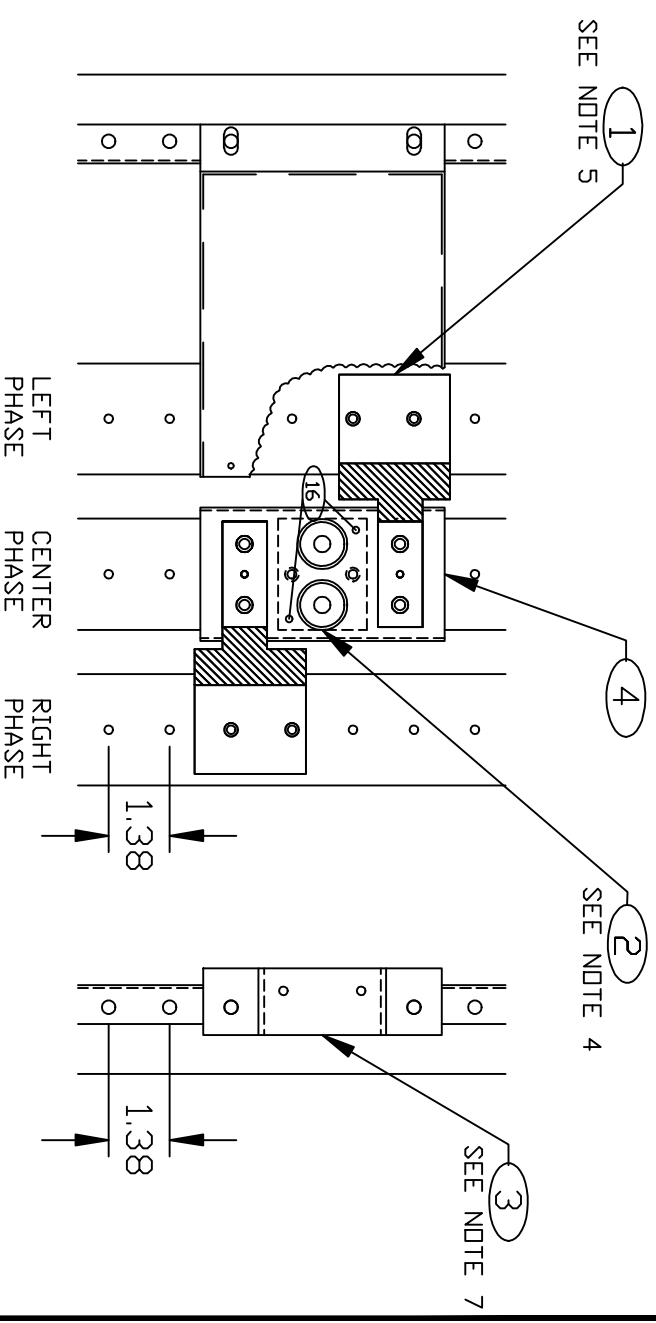

| ITEM | QTY. | DESCRIPTION                      | DWG No.           |
|------|------|----------------------------------|-------------------|
| 1    | 2    | A/C PHASE CONNECTORS             | 21J-A162KD1-00-01 |
| 2    | 1    | B PHASE CONNECTOR                | 21J-A162KD1-00-02 |
| 3    | 2    | BREAKER MOUNTING BRACKET         | 21H-A162LB1-00-03 |
| 4    | 1    | B PHASE CONNECTOR INSULATION     | 21I-FP04-02       |
| 5    | 1    | DEAD FRONT/FILLER PLATE          | 21F-A162LB1-00-05 |
| 6    | 1    | FILLER MOUNTING BRACKET          | 21F-A162LB1-00-06 |
| 7    | 1    | BREAKER DR SWITCH                |                   |
| 8    | 6    | 1/2-20 X 1 1/2" SELF TAP BOLT    |                   |
| 9    | 4    | 1/4-20 X 3/4" HEX HEAD BOLT      |                   |
| 10   | 8    | 1/4" FLAT WASHER                 |                   |
| 11   | 4    | 1/4" STAR NUT                    |                   |
| 12   | 4    | 1/2-20 X 1 1/2" ROUND HEAD SCREW |                   |
| 13   | 2    | 3/8 X 1" SOCKET HEAD BOLT        |                   |
| 14   | 4    | 3/8 X 1 1/2" SOCKET HEAD BOLT    |                   |
| 15   | 6    | 3/8" LDKK WASHER                 |                   |
| 16   | 6    | 3/8 X 1/2" ROUND HEAD SCREW      |                   |



**HRC**  
Hardware Resource Company

TITLE:

CUTLER-HAMMER/WESTINGHOUSE  
400AMP MOUNTING HARDWARE FOR  
KD, HKD, BREAKERS  
IN CDP TYPE PANEL TWIN MOUNT

DRAWING No. 21-A2

KIT No. 21-A162KD1-00

LAYER  
KD1

REV